

BMW Motorrad

Installation Instructions

Retrofit kit, sports cases



Before commencing work, you must read these Installation Instructions through carefully and make sure you understand everything they contain.

To put it as concisely as possible - safety always comes first. It's fun to fit accessories, but accessories add up to much more. Accessories make a standard motorcycle into your custom bike. Now, what about your abilities as a mechanic and your hands-on experience? Are you sure that you have all the special tools you'll need?

Your authorised BMW Motorrad dealer will be happy to install this retrofit kit professionally and at reasonable cost.

We offer our customers a very wide range of type-tested accessories and optional extras. This explains why these Installation Instructions cannot describe all the possible equipment combinations. Consequently, we have concentrated on the basic version of the model in question. The procedures for removing and installing accessory components are described in the applicable sets of installation instructions. Consult your authorised BMW Motorrad dealer if the instructions in question are no longer in your possession.

The symbols used to draw attention to safety instructions in this manual are as follows:



Warning

This symbol indicates precautions and measures which are essential in protecting the rider and other persons from severe or fatal injury.



Attention

Specific instructions and safety precautions intended to prevent damage to the motorcycle and accessories. Non-compliance can void the warranty.



Note

Specific instructions on how to operate, control, adjust or look after items of equipment on the motorcycle.



Tightening torque

Screws, bolts and nuts are tightened in accordance with the applicable DIN/ISO standards. Tightening torques that deviate from the standards are stated. Non-compliance can result in damage to the motorcycle or accessories or can endanger the rider.

- ▶ Start of the main activity
- ▷ Start of the secondary activity
- Instruction

- ◀ End of the main activity
- ◁ End of the secondary activity

© 2006 Copyright by:

BMW Motorrad, Service, D-80788 München

Not to be reproduced, translated or replicated in any way whatsoever, either wholly or in part, without written permission from BMW Motorrad.

Subject to change without notice. Errors and omissions excepted.

All rights reserved.

Retrofit kit, sports cases

Requisite tools

- Set of Torx wrenches

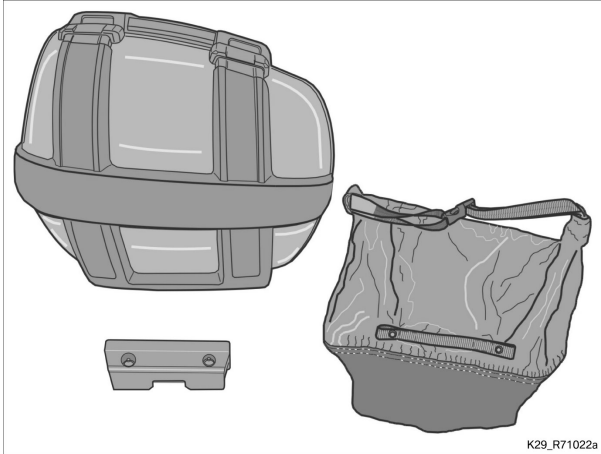

Retrofit kit

- Case
- Bottom anchorage
- Liner
- Installation Instructions

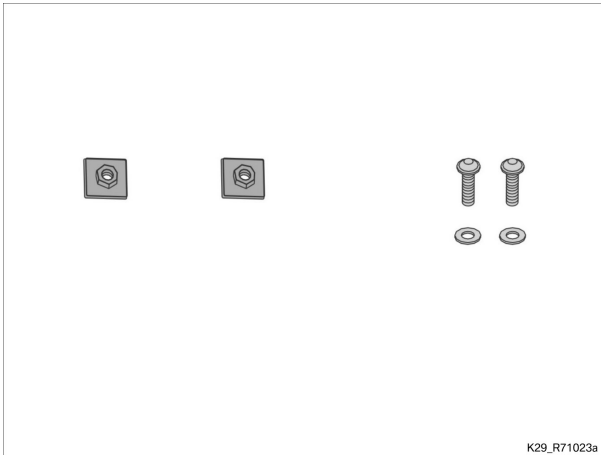

Also required:

- Counter-holder 2 of
- Panhead screw, M6 2 of
- Shim 6 2 of

Also required:

- Lock barrel with key 1 set

1

General instructions



Warning

Sports cases not installed with the BMW sports-case carrier can work loose and impair road safety. Install sports cases only in combination with the BMW sports-case carrier.



Warning

Risk of impaired road safety.
Always comply with the instructions printed on the label in the lid of the sports case and the instructions for loading in the Rider's Manual.

**Attention**

The use of unsuitable cleaning and care products can result in damage to the surfaces.
Use only soapy water and a soft cloth for cleaning.
Do not use other solvents or fuel.

**Warning**

A hot engine can cause burns.
Allow the engine and exhaust to cool before commencing work.

**Attention**

If it is not standing firmly, the motorcycle could topple in the course of the operations described below.
Always make sure that the motorcycle is stable and firmly supported.

**Warning**

Injury to persons
Keep children and household pets well away from the work zone.

**Warning**

Risk of injury by snagging or electrical short-circuit.
Remove all items of personal jewellery (rings, chains, wristwatch, etc.) before commencing work.

**Note**

Once the retrofit kit has been installed by the workshop, these installation instructions must be handed over to the customer.
Make sure that these installation instructions accompany the retrofit kit when it is passed on to a third party.

2

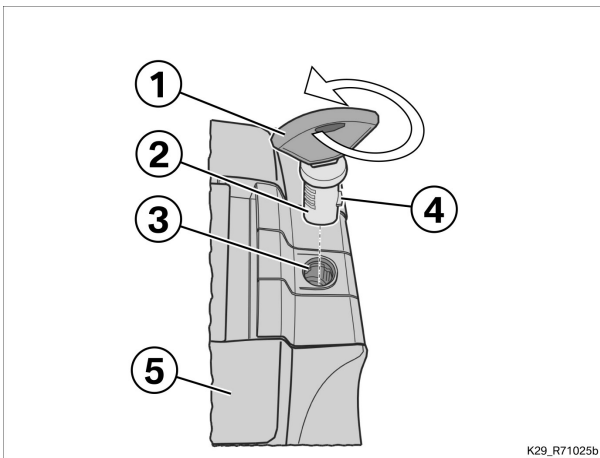

► Installing lock barrel

- Insert key **1** into lock barrel **2**.
- Using the key, insert lock barrel **2** into lock housing **3**, making sure that retainer **4** is toward case bottom **5**.
- Turn lock housing **2** counter-clockwise until retainer **4** engages.

3

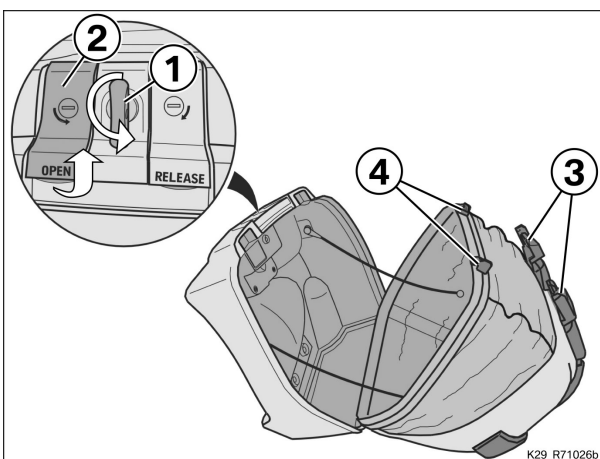

► Opening cases

- Turn key **1** to the OPEN position (see **detail**).
- Pull release lever **2** OPEN up.
- Swing retainers **3** with snaplock ends out.
- Hold release lever **2** (OPEN) in the pulled position or pull it again and open case-volume expander **4**.

4

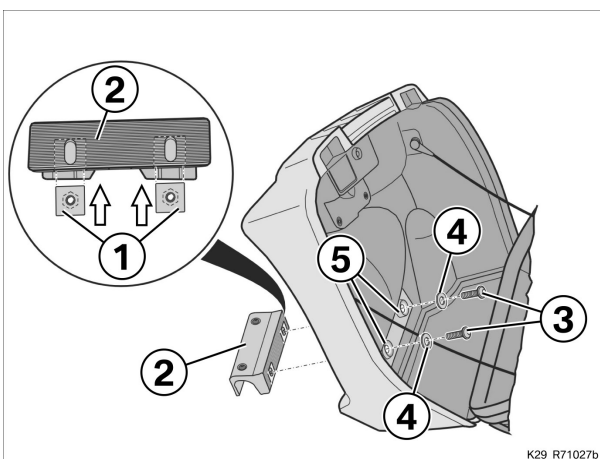

► Preassembling case anchorage

- Seat both counter-holders **1** (metal to the ribbed side of rest) in bottom anchorage **2**.

⚠ Warning

The case can be damaged or can work loose if the screws are installed without washers or if washers other than those provided as part of the retrofit kit are used.

Install only the washers supplied as part of the retrofit kit.

- Install screws **3** with washers **4** in holes **5** in the case bottom.

- Position anchorage **2** complete with counter-holders **1** in recess in case bottom and secure the assembly with screws **3**.

► Adjusting case anchorage

Warning

Inadequately secured cases can impair road safety. Make sure that the cases do not wobble and that there is no play at the anchorages. The bottom anchorage requires adjustment as soon as slight play becomes perceptible after prolonged use.

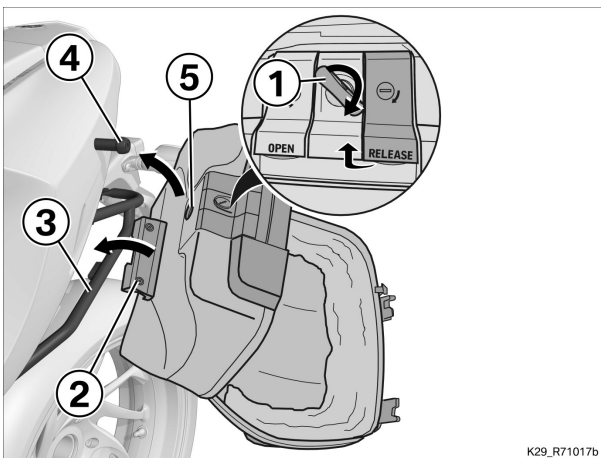

- Open the case and install it on the motorcycle.
- Turn key **1** toward the RELEASE position.
- Engage the case with bottom anchorage **2** on curved tubular section **3**.
- Tilt the case up and seat it on mushroom head **4**, while at the same time pulling the RELEASE lever up until mushroom head **4** is at the rear end of mount **5**, then push the RELEASE lever down.
- Make sure that the mushroom head is now locked.

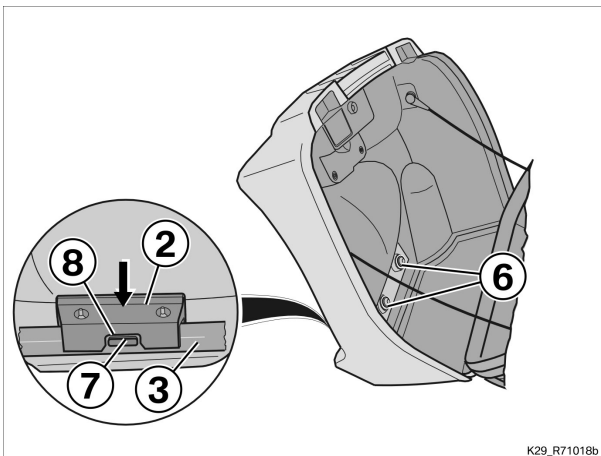

- Slacken screws **6** at bottom anchorage **2**.
- Push bottom anchorage **2** down on curved tubular section, making sure that inboard catch **7** on curved tubular section **3** is in recess **8** in bottom anchorage **2**.
- Tighten screws **6**.

 Tightening torques		
Screw in rest, bottom		
M6	8 Nm	Case carrier

Warning

Risk of impaired road safety. Always comply with the instructions printed on the label in the lid of the sports case and the instructions for loading in the Rider's Manual.

- Do not exceed the maximum permissible payload and the maximum speed limit.

 Technical data			
Payload, sports case		max 8 kg	

 Technical data			
Maximum speed limit with sports cases fitted		max 180 km/h	

- Follow the same procedure to install and adjust the second bottom anchorage on the other side of the motorcycle.



6

Always comply with the regulations regarding approval in the country of use.

 **Note**

For the Federal Republic of Germany:
 No entry required in the vehicle's registration papers.